

### TECHNICAL SPECIFICATIONS

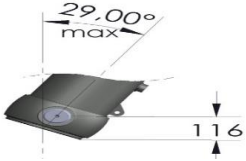

Working volume [lts]	198
Max.Working Pressure[bar]	250
Weight(cylinder)[kgs]	427
Min-Max.Cylinder Capacity [to]	90-100

Stage no	1	2	3	4	5	Total stroke
Ø Stage [mm]	Ø220	Ø197	Ø175	Ø154,5	Ø135	
Stroke [mm]	1375	1375	1375	1375	1375	6875

This cylinder is used to lift up dampers that is loaded different materials, loads must be centerised.

Cylinders should not be used as a main structural purposes be subject to side loads.

Cylinder should be mounted regarding to the instruction that are shown in technical design with working angle description.

Cylinder shouldnot have more than 29 degree angels to return backside.

Cylinder is a cold drawn,seamless tubes which is ST52,E355,DIN2391 BK+S,E10305-2 standarts.

Each stage tubes that is chroame coated with 20 micron,should be protected against the paints and chemicals.

Working temperature is between -40 C and 100 C

Painted by qualified acyriclic materials.

Load capacity described by technical specifications.

Warranty is valid under the working principles and technical specification.

1.Organize Sanayi Bölgesi Budaközü Sokak 16/B ( KONYA) TURKEY

Tel +90 332 251 06 00-Fax +90 332 251 06 00

info@hydotosmotiv.com.tr - www.hydotosmotiv.com.tr

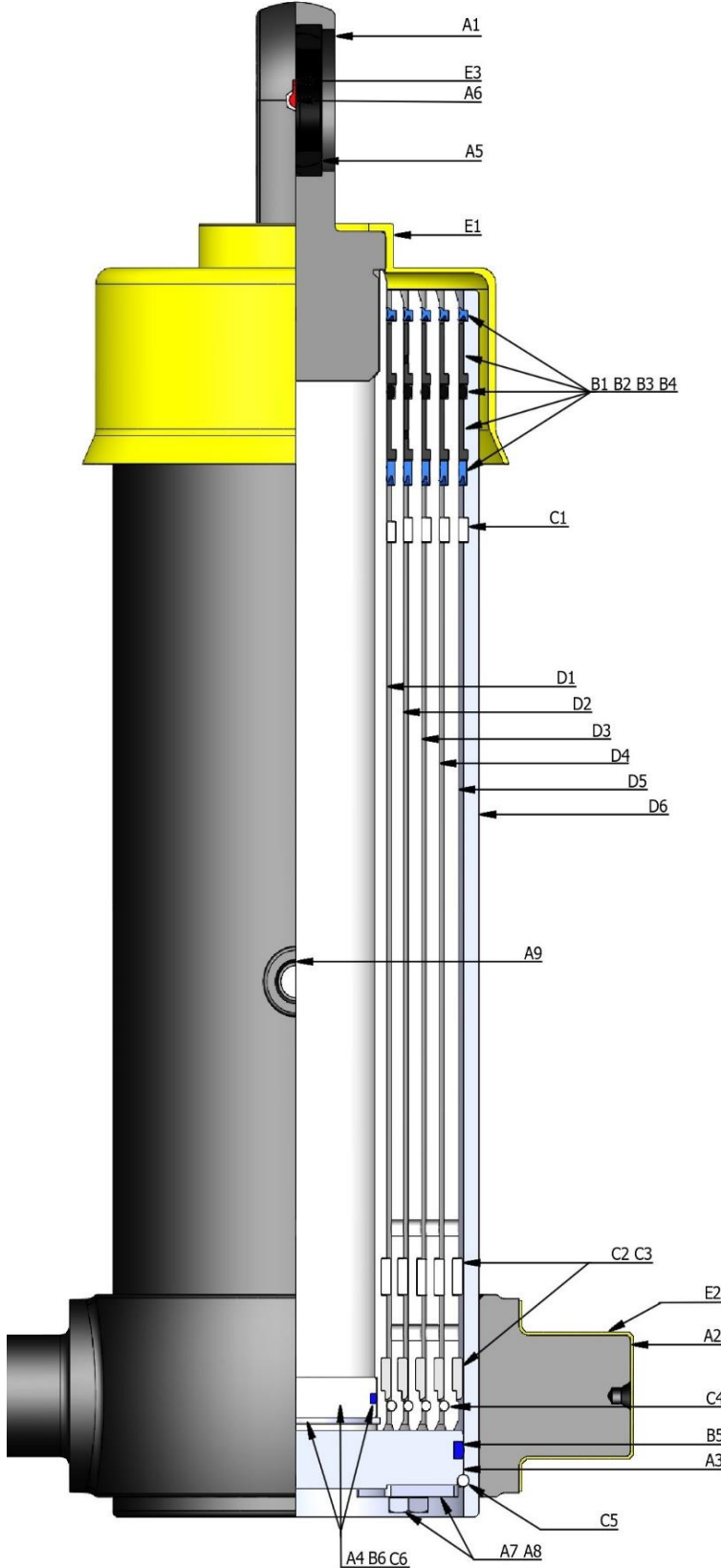

Pos.	Description
------	-------------

A1	PISTON EYE
A2	STELL CONNECTION
A3	PULLER CAP
A4	LAST STAGE BOTTOM CAP
A5	Ø50 SPHERICAL BEARING
A6	M8X1 GREASER
A7	M10 WASHER
A8	M10x20 SCREW
A9	1" OIL INLET

B1	DUST FELT
B2	CUSHIONING
B3	O-RING
B4	NUTRING
B5	FELT COVER
B6	FELT COVER

C1	SFERO CIRCLIP
C2	SFERO CIRCLIP
C3	SFERO CIRCLIP
C4	WIRE CIRCLIP
C5	WIRE CIRCLIP
C6	CIRCLIP

D1	Ø135 STAGE
D2	Ø 154,5 STAGE
D3	Ø175 STAGE
D4	Ø 197 STAGE
D5	Ø220 STAGE
D6	Ø245 BODY

E1	DUST PROTECTION CAP
E2	PROTECTION CAP
E3	GREASER PROTECTION CAP